

# BLDC motor speed controller BLDC-50xxA

## Standard Data

Model	BLDC-5015A	BLDC-5025A
Rated voltage	24-50VDC	24-50VDC
Rated current:	15A	25A
Dimension	80 x 142 x 33,5mm	79 x 151 x 48mm
Ambient temperature	0...+50°C	
Mounting	any	
Speed adjustment	internal potentiometer or analog DC input	
Features	Brake, CW/CCW, hall sensor input	



## Performance Data

Rated Current	15A	25A
Peak current	45A	45A
Hall sensor angle	120°, 240°	120°, 240°
Output power	max. 350W	max. 750W

Protection over current control

## Wiring diagramm

BLDC-5015A

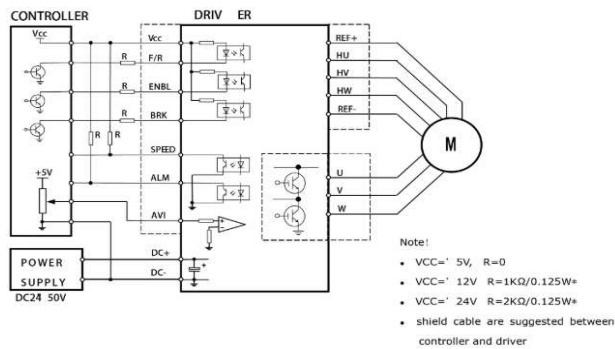

BLDC-5025A

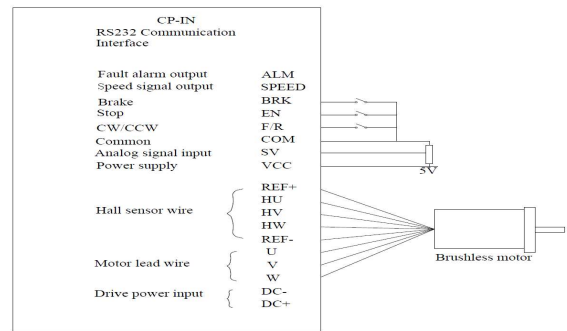

## Dimension

